

FITTURE																													
NAME	ORBITAL TRIMLESS "SPEAKER"																												
REFERENCE	650346 TEXT. BLACK 2700K 650347 TEXT. WHITE 2700K 650366 TEXT. BLACK 3000K* 650367 TEXT. WHITE 3000K* 650386 TEXT. BLACK HALOSPHERE** 650387 TEXT. WHITE HALOSPHERE**																												
SPECIFICATIONS (luminaire)	<table border="1"> <tr> <td>Safe distance to object</td> <td> - 0,1m - </td> </tr> <tr> <td>Lamptype</td> <td>Annular LED array</td> </tr> <tr> <td>CCT</td> <td>2700K/3000K*/3000K&gt;1800K**</td> </tr> <tr> <td>Luminous flux</td> <td>1460lm/1486lm*/1230lm**</td> </tr> <tr> <td>Power</td> <td>12,3W/12,7W**</td> </tr> <tr> <td>Current</td> <td>350mA</td> </tr> <tr> <td>Forward voltage</td> <td>35,1V/36V**</td> </tr> <tr> <td>Symbol</td> <td></td> </tr> <tr> <td>Gear</td> <td>Converter not incorporated</td> </tr> <tr> <td>Orientability</td> <td>None</td> </tr> <tr> <td>Dimmability</td> <td>CCR, PWM dimmable/CCR dimmable**</td> </tr> <tr> <td>Beamangle</td> <td>120°</td> </tr> <tr> <td>CRI - SDCM</td> <td>92/87** - 3</td> </tr> <tr> <td>Class - IP</td> <td> IP20</td> </tr> </table>	Safe distance to object	- 0,1m -	Lamptype	Annular LED array	CCT	2700K/3000K*/3000K>1800K**	Luminous flux	1460lm/1486lm*/1230lm**	Power	12,3W/12,7W**	Current	350mA	Forward voltage	35,1V/36V**	Symbol		Gear	Converter not incorporated	Orientability	None	Dimmability	CCR, PWM dimmable/CCR dimmable**	Beamangle	120°	CRI - SDCM	92/87** - 3	Class - IP	IP20
Safe distance to object	- 0,1m -																												
Lamptype	Annular LED array																												
CCT	2700K/3000K*/3000K>1800K**																												
Luminous flux	1460lm/1486lm*/1230lm**																												
Power	12,3W/12,7W**																												
Current	350mA																												
Forward voltage	35,1V/36V**																												
Symbol																													
Gear	Converter not incorporated																												
Orientability	None																												
Dimmability	CCR, PWM dimmable/CCR dimmable**																												
Beamangle	120°																												
CRI - SDCM	92/87** - 3																												
Class - IP	IP20																												
(speaker)	<table border="1"> <tr> <td>Drive unit</td> <td>3" Full range speaker</td> </tr> <tr> <td>Maximum power input</td> <td>30W</td> </tr> <tr> <td>Rated power input</td> <td>15W</td> </tr> <tr> <td>Nominal impedance</td> <td>8Ω</td> </tr> <tr> <td>DCR impedance</td> <td>6,6Ω</td> </tr> <tr> <td>sensitivity 1W/1m</td> <td>88dB</td> </tr> <tr> <td>Frequency response</td> <td>75Hz - 20kHz</td> </tr> </table>	Drive unit	3" Full range speaker	Maximum power input	30W	Rated power input	15W	Nominal impedance	8Ω	DCR impedance	6,6Ω	sensitivity 1W/1m	88dB	Frequency response	75Hz - 20kHz														
Drive unit	3" Full range speaker																												
Maximum power input	30W																												
Rated power input	15W																												
Nominal impedance	8Ω																												
DCR impedance	6,6Ω																												
sensitivity 1W/1m	88dB																												
Frequency response	75Hz - 20kHz																												
(mechanical)	<table border="1"> <tr> <td>Application</td> <td> Interior - Ceiling Mounted</td> </tr> <tr> <td>Installation</td> <td>Frame with springs</td> </tr> <tr> <td>Weight</td> <td> (1,1)</td> </tr> </table>	Application	Interior - Ceiling Mounted	Installation	Frame with springs	Weight	(1,1)																						
Application	Interior - Ceiling Mounted																												
Installation	Frame with springs																												
Weight	(1,1)																												
ACCESSORY (required for installation)																													
NAME	ORBITAL TRIMLESS FRAME																												
REFERENCE	701112																												

INSTALLATION

**A** ORBITAL TRIMLESS IN PLASTERBOARD (HOLLOW CEILINGS)

① Make hole size Ø140mm (min. depth: 130mm)

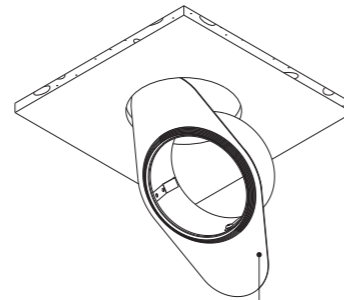

② Screw to ceiling & level the orbital plasterkit

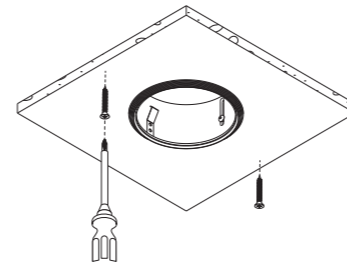

③ Plaster the edge and paint the ceiling

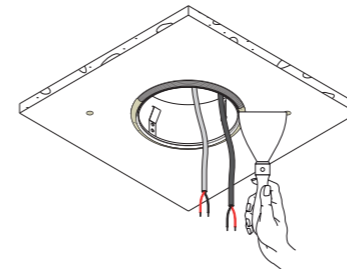

701112  
Orbital trimless frame

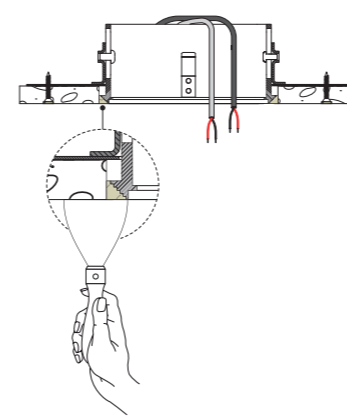
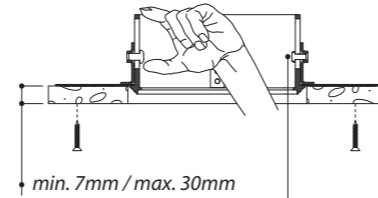

**B** ORBITAL TRIMLESS ON PLASTERBOARD (SOLID CEILINGS)

① Make hole size Ø140mm (min. depth: 105mm)

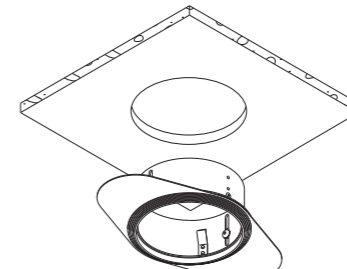

② Screw to ceiling & level the orbital plasterkit



③ Plaster and paint the ceiling

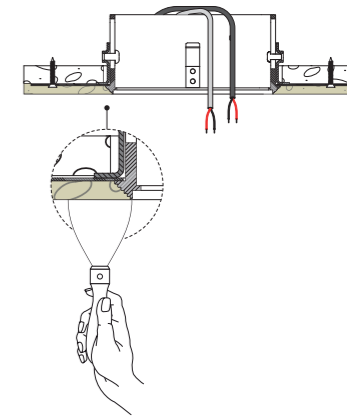
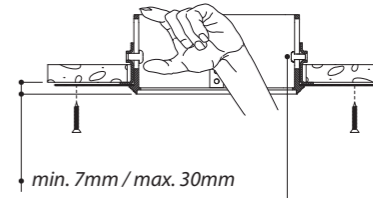
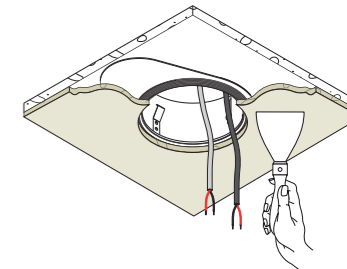

④ Connect the speaker to an amplifier (a) & make electrical connection with the luminaire (b)

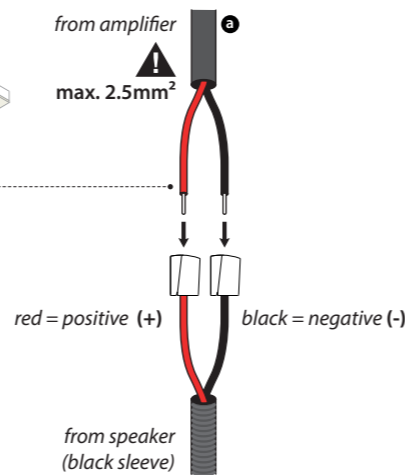
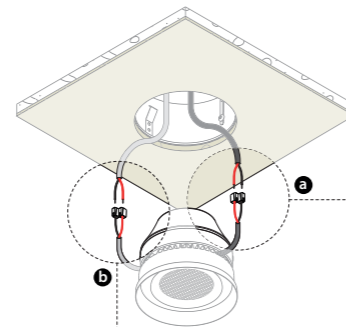

ALWAYS DISCONNECT MAINS POWER SUPPLY FROM CONVERTER BEFORE SWITCHING "ON" LED LUMINAIRES TO PREVENT HOT PLUGGING ISSUES!

⑤ Push the luminaire gently into the frame

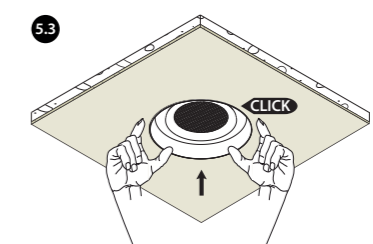
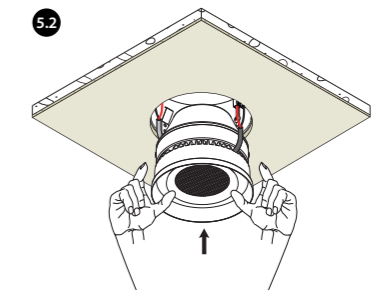
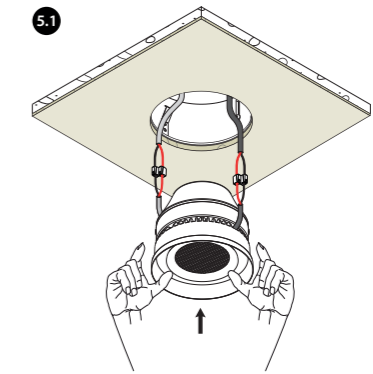

⑦ Switch on mains power supply & turn on the amplifier

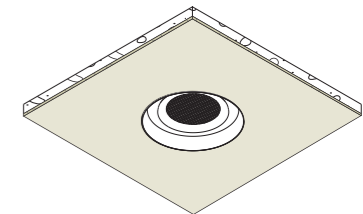

NL Installatie- en onderhoudsrichtlijnen m.b.t. de fabrieksgarantie.  
1. De plaatsing, de aansluiting en het uittesten van dit toestel dient steeds te gebeuren door een erkend elektro-installeator.  
2. Dit toestel moet geïnstalleerd, verbonden en getest worden volgens de nationaal geldende reglementen op elektrische installaties.  
3. De technische bijsluiter dient te worden beschouwd als een onderdeel van de algemene verkoopsvoorwaarden van TAL nv.  
4. De elektro-installeator is verantwoordelijk voor het gebruik van compatibele voorschakelapparatuur die voldoen aan de geldende IEC normen.  
5. Reinig het toestel enkel met een zachte en lichtvochtige doek zonder reinigingsmiddel.  
6. Schakel altijd eerst de elektriciteit uit alvorens het toestel te plaatsen en te installeren.

EN Installation and maintenance instructions regarding the manufacturer's warranty.  
1. Installation, connection and testing of this product must always be performed by a certified electrician.  
2. This product must be installed, connected and tested in accordance with the applicable national regulations for electrical installations.  
3. The technical manual must be regarded as part of the general sales conditions of TAL nv.  
4. The electrical installer is responsible for the use of compatible control gear that meets the applicable IEC standards.  
5. Only clean the device with a soft and slightly moist cloth without detergent.  
6. Always switch off the electricity supply before installing and connecting the product.

DE Installations- und Wartungsanweisungen bezüglich der Herstellergarantie.  
1. Installation, Anschluß und Prüfung dieses Geräts soll nur von einem anerkannten Elektriker ausgeführt werden.  
2. Dieses Gerät soll in Übereinstimmung mit den nationalen geltenden Vorschriften für Elektroinstallationen installiert, angeschlossen und geprüft werden.  
3. Die technische Anleitung muß als Teil der allgemeinen Verkaufsbedingungen von TAL nv betrachtet werden.  
4. Der Elektroinstallateur ist verantwortlich für die Verwendung von kompatiblen Betriebsgeräten, die den geltenden IEC-Normen entsprechen.  
5. Reinigen Sie das Gerät nur mit einem weichen und leicht feuchten Tuch ohne Reinigungsmittel.  
6. Schalten Sie den Strom immer aus, bevor Sie das Gerät installieren und anschließen.

FR Instructions d'installation et d'entretien concernant la garantie du fabricant.  
1. L'installation, la connexion et les essais de cet appareil doivent toujours être effectués par un électricien reconnu.  
2. Cet appareil doit être installé, raccordé et testé conformément aux réglementations nationales pour les installations électriques.  
3. La notice technique doit être considérée comme faisant partie des conditions générales de vente de TAL SA.  
4. L'installateur électrique est responsable de l'utilisation d'un équipement de contrôle compatible qui satisfait aux normes CEI applicables.  
5. Nettoyez l'appareil uniquement avec un chiffon doux et légèrement humide sans détergent.  
6. Éteignez toujours l'électricité avant d'installer et de connecter l'appareil.